

ASSEMBLY INSTRUCTION  
LA SALLE MK2 LARGE COFFEE TABLE  
ITEM CODE 65191

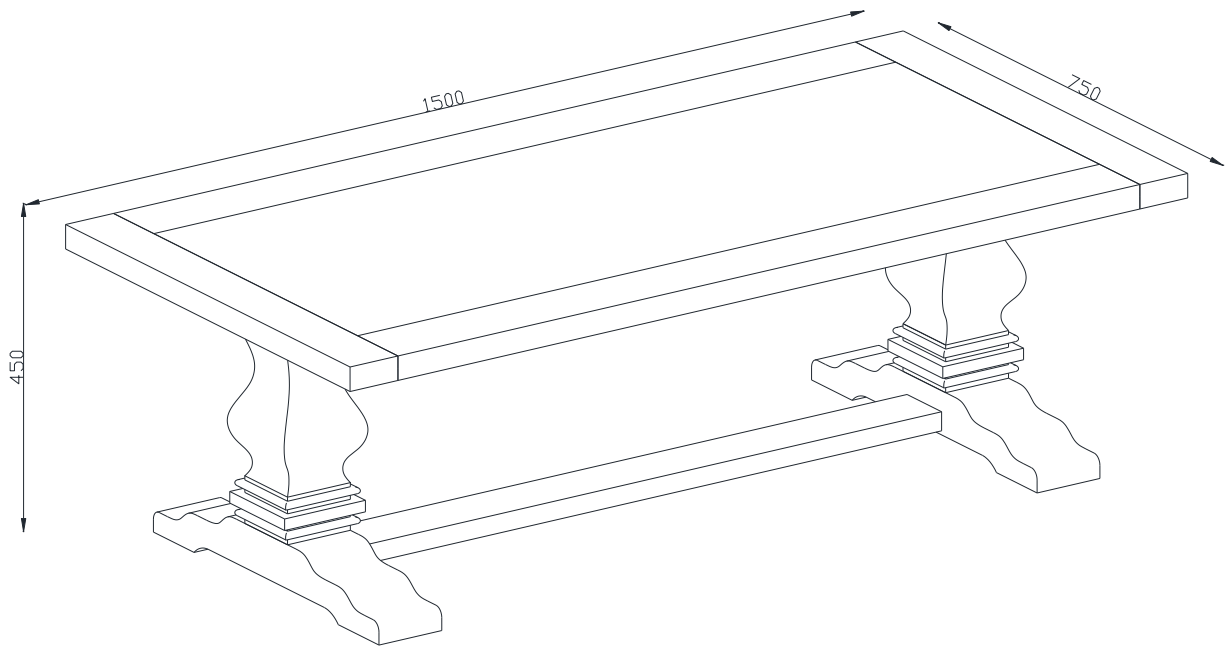

Imported by Amart Furniture Pty Ltd, Qld, Brisbane Australia.  
For any assistance with assembly or for missing parts please phone  
Amart Furniture, Customer Service Free call 1800 351 084

## **IMPORTANT: CARE GUIDE FOR YOUR TIMBER FURNITURE**

- *Congratulations! You have just purchased a quality product from Amart Furniture. Please read on for important information regarding your purchase.*
- A multi-step finish is applied to all our furniture, but all wood comes from nature. Because of this, there will be natural variations in surface texture and grain like knots, mineral streaks and sap runs that may affect the finish.
- These differences in character are not defects, but distinctions that make each piece of furniture unique.
- Our furniture is built to last. Following these steps for basic care should protect your investment for years to come.
- Dust frequently with a clean damp lint-free cloth. This will help remove abrasive build up which can damage a finish over time.
- Do not place hot objects on any furniture surface. Always use a **coaster** or placemat. Laminate and lacquer finishes on table tops provide added scratch and heat resistance to our furniture, but they can still be damaged without proper care.
- Avoid exposing your furniture to strong sunlight, heat outlets, open windows or dampness. Prolonged exposure to direct sunlight can fade the finish of your furniture, while extreme temperature and humidity changes can cause cracking or splitting.
- Do not expose your furniture to any liquids. Never allow water to sit on your furniture. Alcohol, nail polish and perfume are also dangerous as they will dissolve the lacquer finish on contact and may require professional repairs.
- Do not allow plastic to come in direct contact with your furniture. Chemicals in the plastic of placemats etc may soften and mark the finish if left in contact with the furniture for a period of time.

## PRE-ASSEMBLY PREPARATION

### Before you start:

1. Choose a clean, level, spacious assembly area. Avoid hard surfaces that may damage the product
2. Take care when lifting. Product should be assembled as near as possible to the point of use
3. Ensure that you have all required contents for complete assembly
4. Always read the assembly instructions carefully before beginning assembly.
5. Keep all hardware parts and packaging out of reach of small children.
6. Do not over tighten the screws and bolts as this may damage the threads



Allow at least 45min







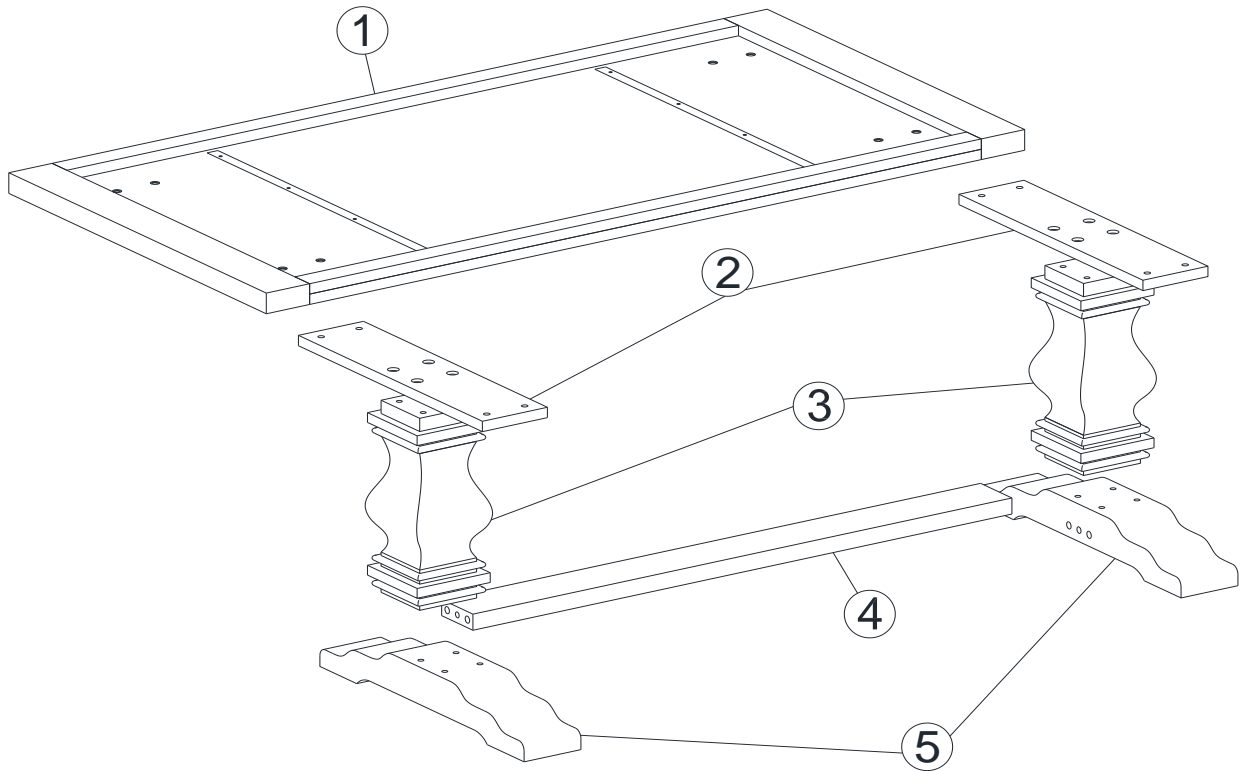

you will need 2 people

# PARTS LIST



Part	DESCRIPTION	Qty	In box	Part	DESCRIPTION	Qty	In box
1	TABLE TOP	1	1	4	CROSS BAR	1	1
2	RAILS	2	1	5	LEGS	2	2
3	PEDESTALS	2	2				

<p>A M6 X 30 BOLT 16 PCES</p> 	<p>B M6 X 80 BOLT 8 PCES</p> 	<p>C M8 X 50 BOLT 2 PCES</p> 	<p>D CURVED WASHER 2 PCES</p> 
<p>E M6.5 X 19 FLAT WASHER 24 PCES</p> 	<p>F M6.5 X 9 SPRING WASHER 24 PCES</p> 	<p>G ALLEN KEY 1 PCE</p> 	

## Step 1

You should have started by opening box 1, upside down. **Keep the table top inside the box** until later advised. Open the legs box as the hardware is in there.

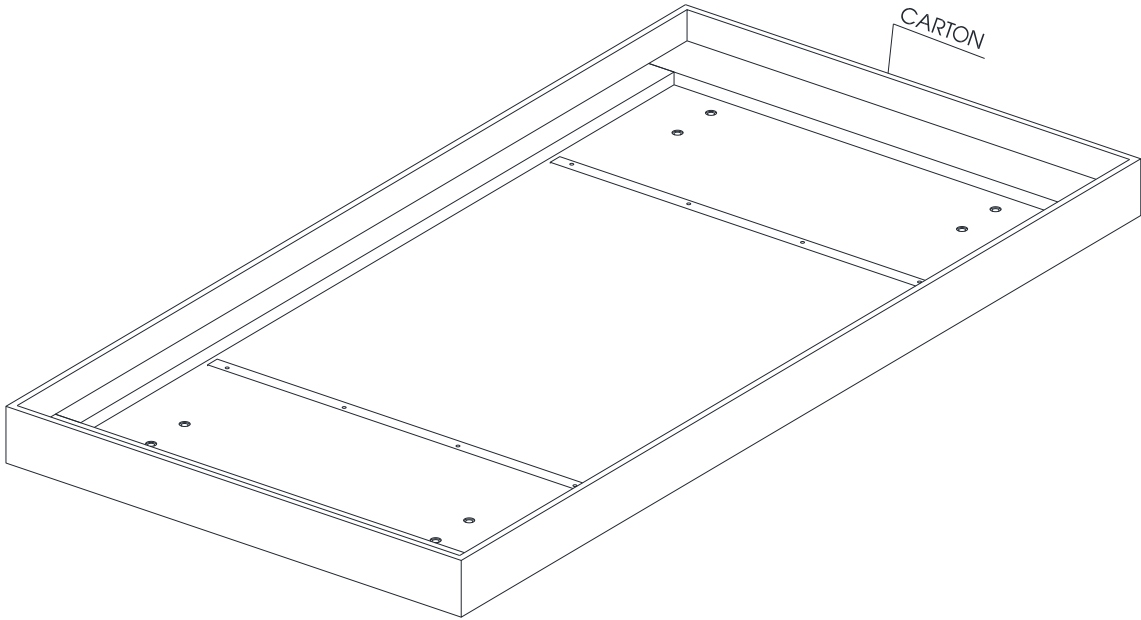



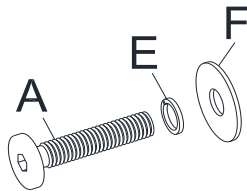

## Step 2

Next you will need to assemble the M6 x 30 bolts (item A) with the M6.5 x 9 spring washers (item F) and the M6.5 x 19 flat washers (item E)



### YOU WILL NEED

A M6 X 30 BOLT 8 PCES 	E M6.5 X 19 FLAT WASHER 8 PCES 	F M6.5 X 9 SPRING WASHER 8 PCES 	G ALLEN KEY 1 PCE 
---	--	---	---

### Step 3

With the assembled bolts from step 2, attach a rail (part 2) to a pedestal (part 3) as per diagram below. Make sure the pedestal is standing upright at all times as shown, we recommend 2 people for this, with one holding the pedestal at all times. Fasten firmly, but do not over tighten, over tightening may damage the surface of the item.

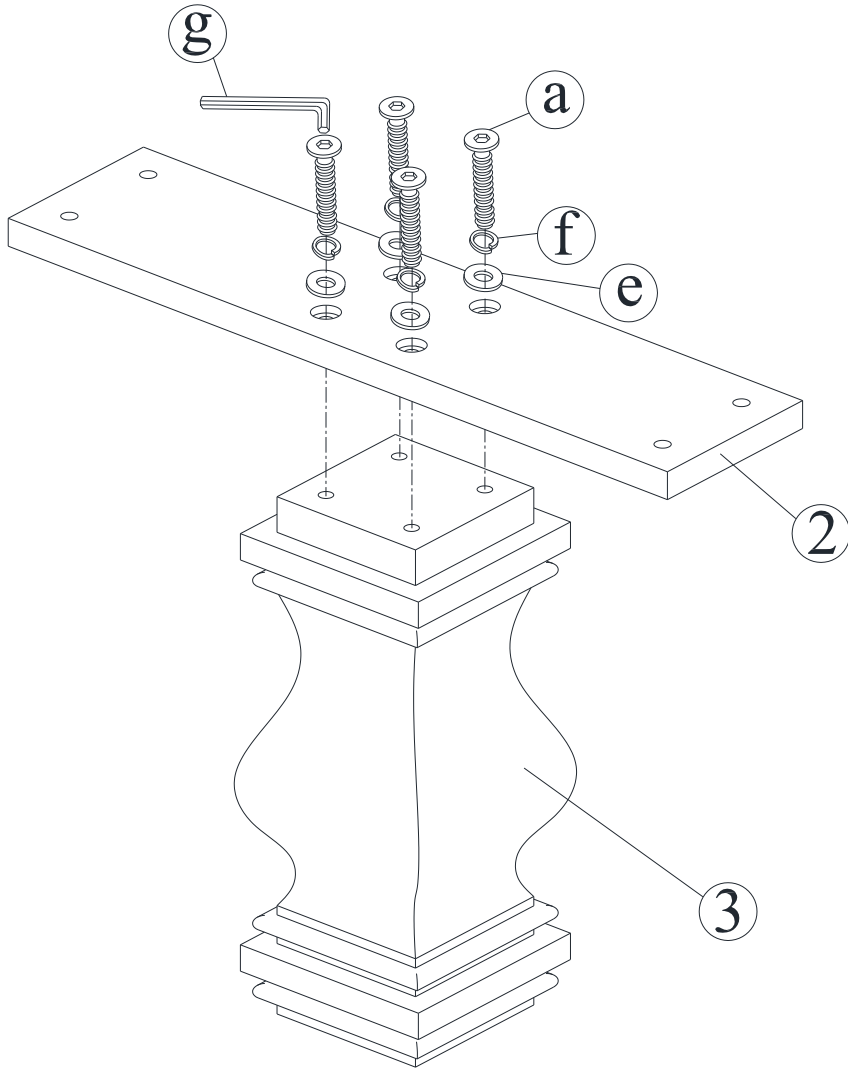

### Step 4



Repeat Step 3, with the remaining rail and pedestal. You should be left with 8 sets of the assembled bolts from step 2, you will need them for step 8

## Step 5

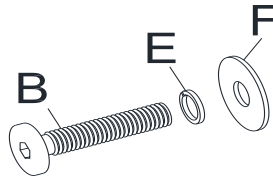
Next you will need to assemble the M6 x 80 bolts (item B) with the M6.5 x 9 spring washers (item F) and the M6.5 x 19 flat washers (item E)

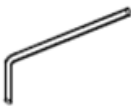

### YOU WILL NEED

B M6 X 80 BOLT 16 PCES 	E M6.5 X 19 FLAT WASHER 16 PCES 	F M6.5 X 9 SPRING WASHER 16 PCES 	G ALLEN KEY 1 PCE 
--	---	--	---

## Step 6

With the assembled bolts from step 5, attach a leg (part 5) to a pedestal (part 3) as per diagram below. Make sure the pedestal is standing upright at all times as shown, we recommend 2 people for this, with one holding the pedestal at all times. Fasten firmly, but do not over tighten, over tightening may damage the surface of the item.

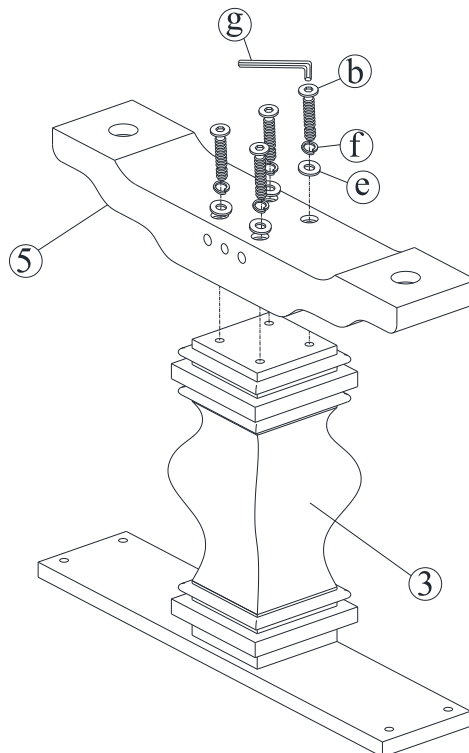

## Step 7

Repeat Step 6 with the other leg and pedestal.

## Step 8

Next we'll be attaching the leg structures to the table top. We recommend 2 people for this with one person holding the leg structure up right at all times. take the 8 remaining assembled bolt sets from step 2. Affix the leg structure to the table top with these using the Allen key provided (item G), as per the diagram below. Fasten firmly, but do not over tighten, over tightening may damage the surface of the item. Repeat for the other side.

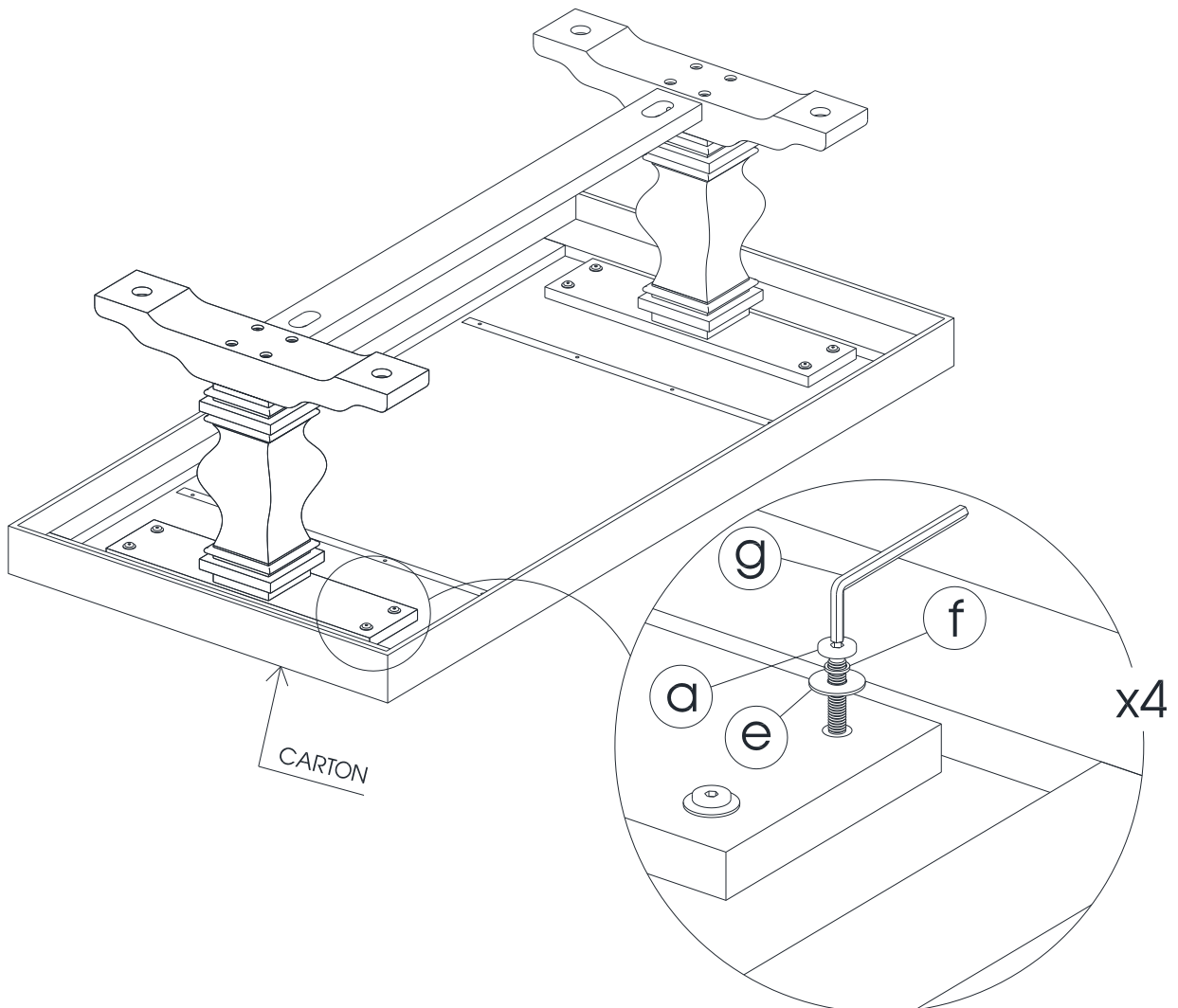



## Step 9

Next we'll be attaching the cross bar. You will require 2 people for this step. One to fasten one end whilst the other holds the other end in place. Due to the space constraint of the slotted hole, please be patient whilst fastening the bolt. Start by placing the curved washer (item D), into place as shown below, then insert the bolt (item C) and fasten. Fasten firmly, but do not over tighten, over tightening may damage the surface of the item. Repeat for the other side.

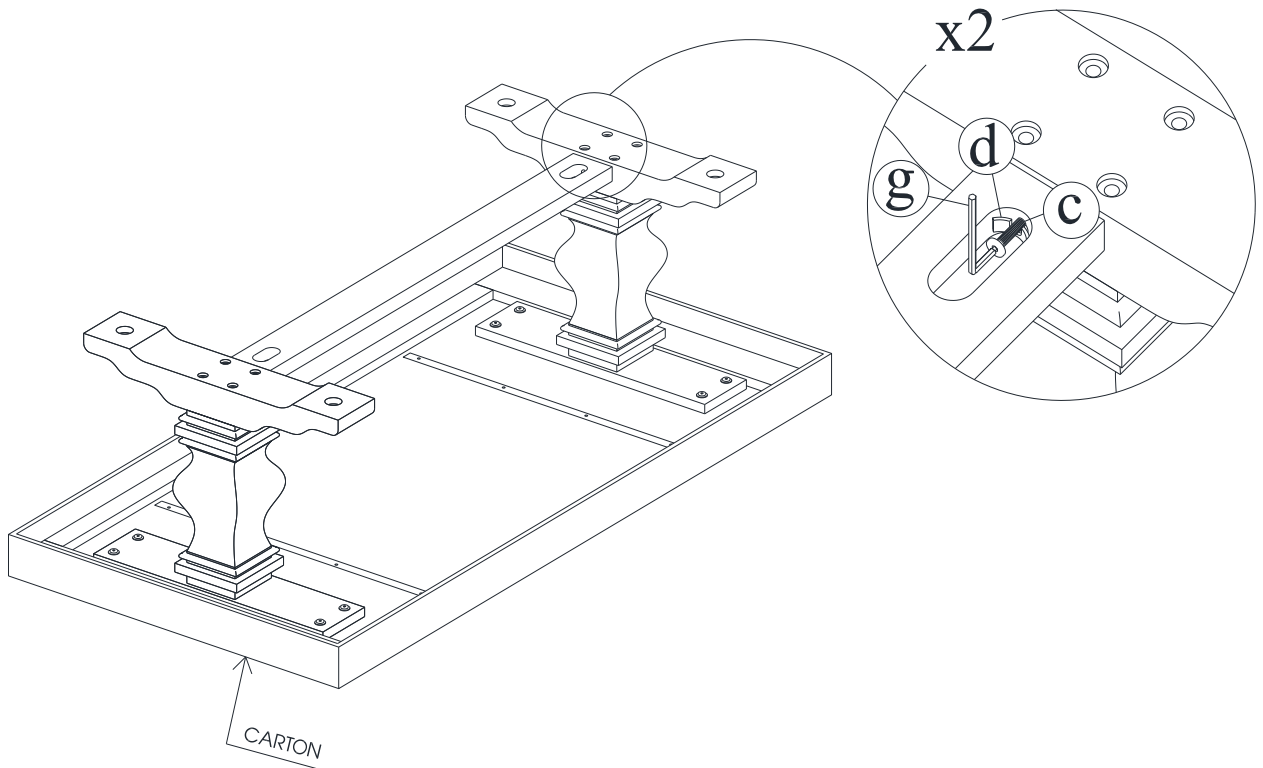

## Step 10

Finally flip the coffee table over. **This is a 2 person task do not do this alone.** Once the right way up, remove the packaging from the table top.

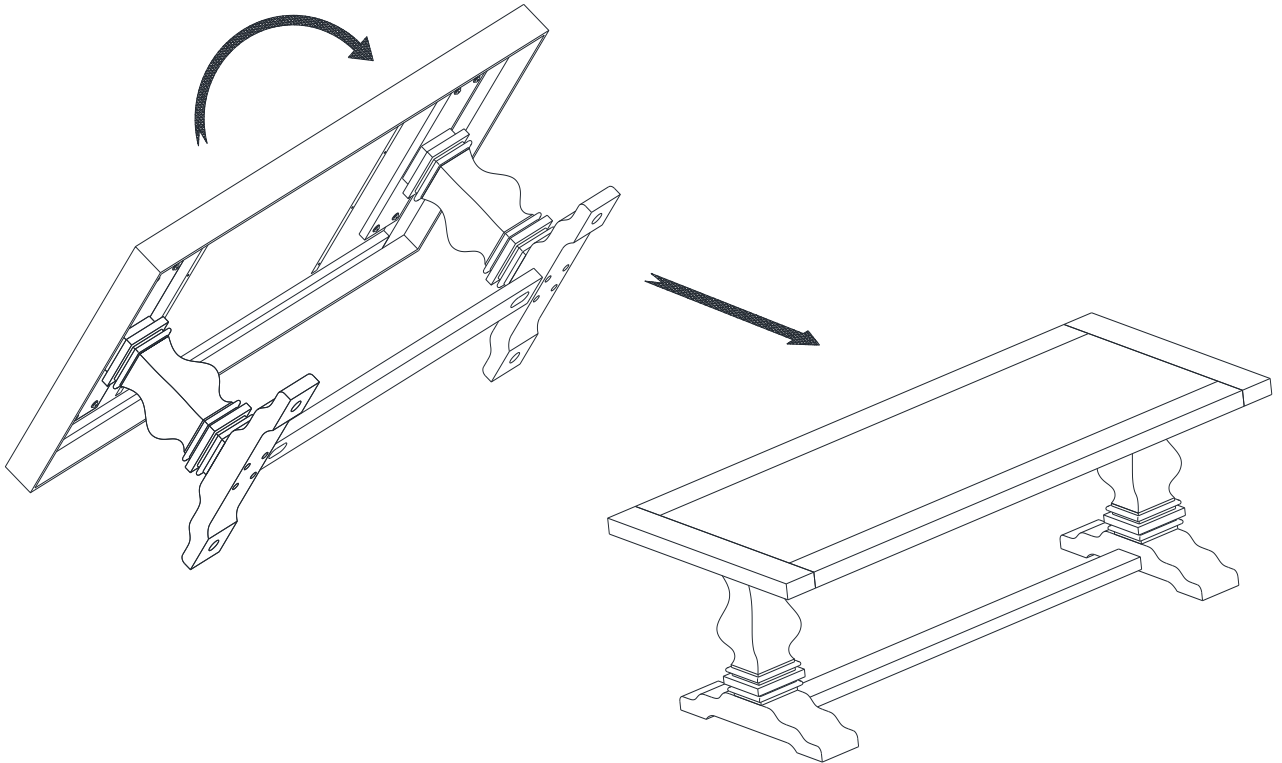

**Assembly is complete.**

